

# Microcontroller programming (with PIC microcontrollers)

# Why PIC?

- Lots of types of microcontrollers
- PICs are very popular, over 8 billion sold

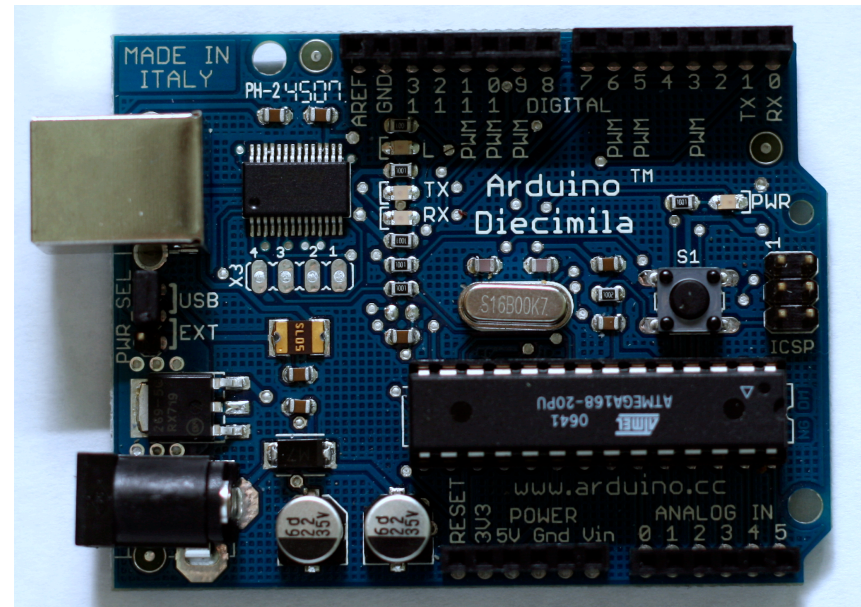

# So it's just C? That sounds simple...

- Harvard architecture—separate data (RAM) and program (Flash ROM) address spaces
- Low resources: 65K ROM, 4K RAM, maximum of 32 calls stack depth, and 256 bytes of stack data, 10 million instructions/sec max
- Access of stack data is, shall we say, leisurely...

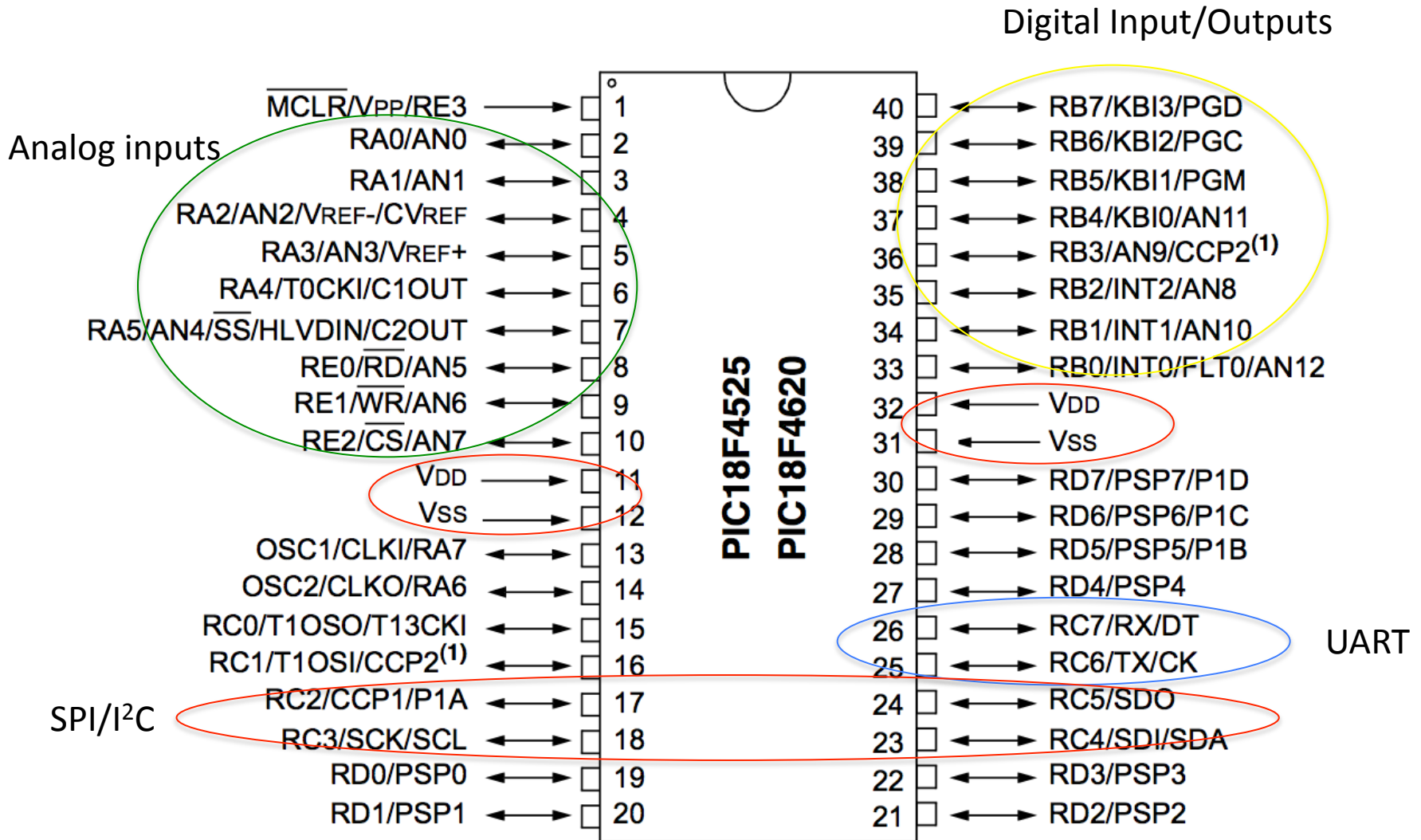

# Schematic

